

## MOS INTEGRATED CIRCUIT

### PRELIMINARY DATA

#### RHYTHM GENERATOR

- LOW POWER DISSIPATION: < 120 mW
- DRIVES 8 SOUND GENERATORS (INSTRUMENTS)
- 12 PROGRAMMABLE RHYTHMS (ALSO AVAILABLE IN COMBINATION)
- MASK PROGRAMMABLE RESET COUNTS: 24 or 32
- DOWN BEAT OUTPUT
- EXTERNAL RESET
- OPEN DRAIN OUTPUTS
- STANDARD MUSIC CONTENT AVAILABLE
- TECHNICAL NOTE NO 131 AVAILABLE FOR FULL INFORMATION

The M 253 is a monolithic rhythm generator specifically designed for electronic organs and other musical instruments.

Constructed on a single chip using low threshold P - channel silicon gate technology it is supplied in a 24 - lead dual in-line ceramic or plastic package.

#### ABSOLUTE MAXIMUM RATINGS

$V_{GG}^*$	Source supply voltage	-20 to 0.3	V
$V_i^*$	Input voltage	-20 to 0.3	V
$I_o$	Output current (at any pin)	3	mA
$T_{stg}$	Storage temperature	-65 to 150	°C
$T_{op}$	Operating temperature	0 to 70	°C

\* This voltage is with respect to  $V_{SS}$  pin voltage

**ORDERING NUMBERS:** M 253 B1 XX for dual in-line plastic package  
 M 253 D1 XX for dual in-line ceramic package  
 M 253 B1 or D1 AA for standard music content

#### MECHANICAL DATA

Dimensions in mm

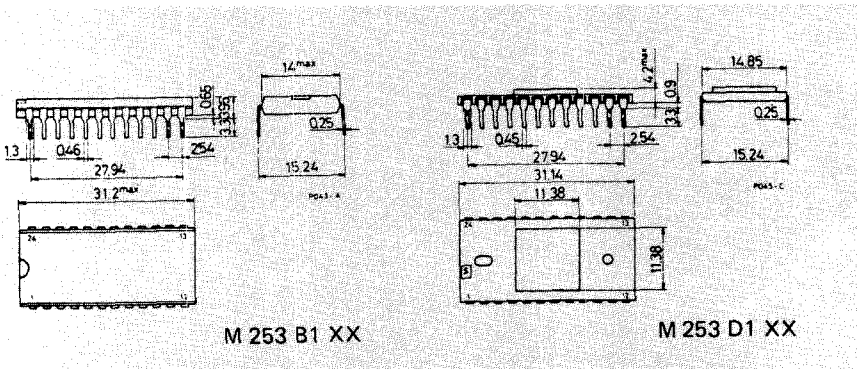

# M 253

## CONNECTION DIAGRAMS (top view)

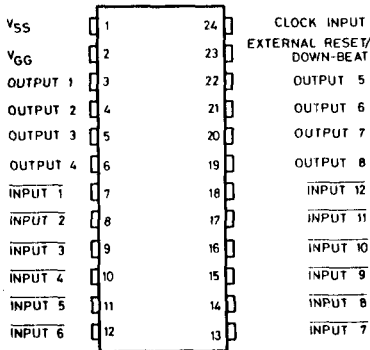

5-1038/1

## M 253 D1 or B1 - AA Standard content configuration

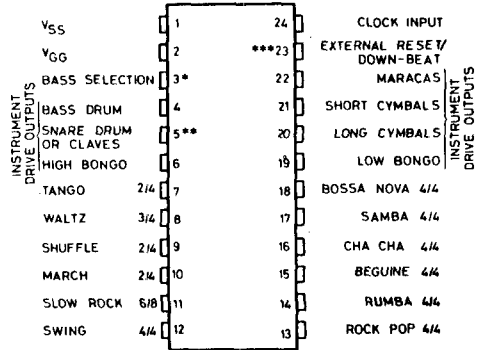

5-1045/1

- \* This output allows the musician to obtain a "basso alternato" accompaniment using two notes of his choice.
- \*\* This output must be connected so as to drive the "snare drum" when the rhythms corresponding to pins 7, 8, 9, 10, 11, 12 and 13 are generated, and the "claves" when the rhythms corresponding to pins 14, 15, 16, 17 and 18 are generated. It can also be used to modulate a chord played on the organ.
- \*\*\* This pin generates a down-beat trigger which can be used to drive an external lamp to indicate the start of each measure.

## BLOCK DIAGRAM

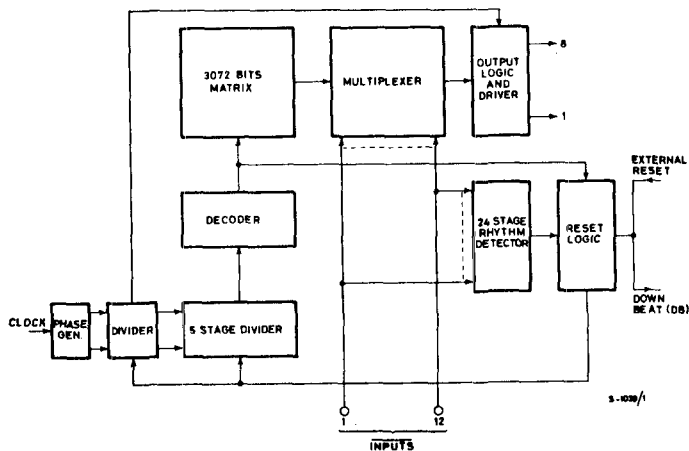

**STATIC ELECTRICAL CHARACTERISTICS**(positive logic,  $V_{GG} = -11.4$  to  $-12.6V$ ,  $V_{SS} = 4.75$  to  $5.25V$ ,  $T_{amb} = 0$  to  $70$  °C unless otherwise specified)

Parameter	Test conditions	Min.	Typ.	Max.	Unit
-----------	-----------------	------	------	------	------

## CLOCK INPUT

$V_{IH}$	Clock high voltage		$V_{SS}-1.5$	$V_{SS}$	V
$V_{IL}$	Clock low voltage		$V_{GG}$	$V_{SS}-4.1$	V

## DATA INPUTS ( $\overline{IN1} \dots \overline{IN12}$ )

$V_{IH}$	Input high voltage		$V_{SS}-1.5$	$V_{SS}$	V
$V_{IL}$	Input low voltage		$V_{GG}$	$V_{SS}-4.1$	V
$I_{LI}$	Input leakage current	$V_i = V_{SS}-10V$ $T_{amb} = 25^\circ C$		10	$\mu A$

## EXTERNAL RESET

$V_{IH}$	Input high voltage		$V_{SS}-1.5$	$V_{SS}$	V
$V_{IL}$	Input low voltage		$V_{GG}$	$V_{SS}-4.1$	V
$R_{IN}$	Internal resistance to $V_{GG}$	$V_o = V_{SS}-5V$	400	600	k $\Omega$

## DATA OUTPUTS

$R_{ON}$	Output resistance	$V_o = V_{SS}-1$ to $V_{SS}$	250	500	$\Omega$
$V_{OH}$	Output high voltage	$I_L = 1$ mA	$V_{SS}-0.5$	$V_{SS}$	V
$I_{LO}$	Output leakage current	$V_i = V_{IH}$ $V_o = V_{SS}-10V$ $T_{amb} = 25^\circ C$		10	$\mu A$

## POWER DISSIPATION

$I_{GG}$	Supply current	$T_{amb} = 25^\circ C$	7	15	mA
----------	----------------	------------------------	---	----	----

# M 253

Output voltage vs. external supply voltage ( $V_{EXT}-V_{SS}$ )

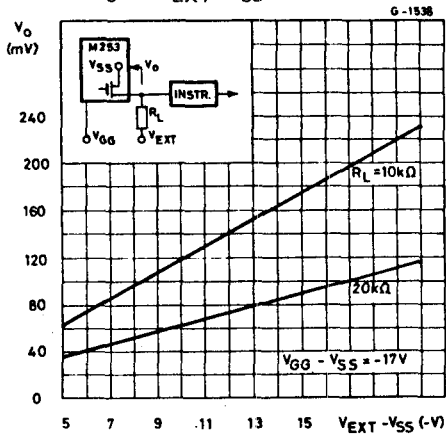

Output voltage vs. supply voltage ( $V_{GG}-V_{SS}$ )

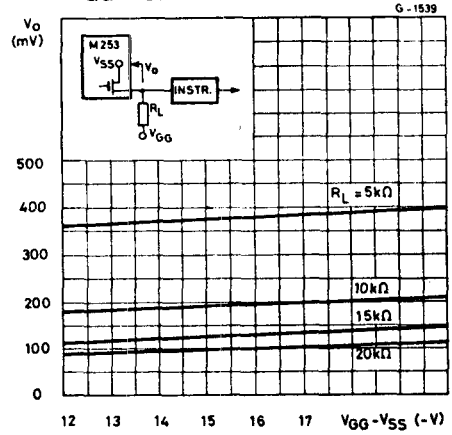

Output dynamic resistance vs. output voltage

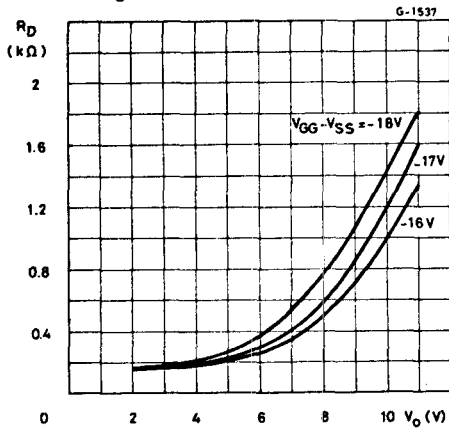

**DYNAMIC ELECTRICAL CHARACTERISTICS** (positive logic,  $V_{GG} = -11.4$  to  $-12.6V$ ,  $V_{SS} = 4.75$  to  $5.25V$ ,  $T_{amb} = 0$  to  $70\text{ }^\circ\text{C}$  unless otherwise specified)

Parameter	Test conditions	Min.	Typ.	Max.	Unit
-----------	-----------------	------	------	------	------

**CLOCK INPUT**

Parameter	Test conditions	Min.	Typ.	Max.	Unit
f	Clock repetition rate	DC	100		kHz
$t_{pw}^*$	Pulse width	5			$\mu\text{s}$
$t_r^{**}$	Rise time		100		$\mu\text{s}$
$t_f^{**}$	Fall time		100		$\mu\text{s}$

**EXTERNAL RESET**

$t_{pw}$	Pulse width	5			$\mu\text{s}$
----------	-------------	---	--	--	---------------

\* Measured at 50% of the swing

\*\* Measured between 10% and 90% of the swing

**TIMING WAVEFORMS** (positive logic)

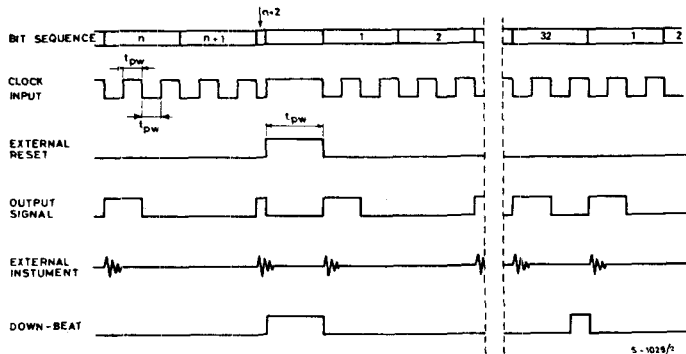

Note: In these timing waveforms it has been assumed, for example, that in the truth table bits  $n + 1$  and  $2$  have not been programmed i.e. the musical instrument has not been introduced. All the other bits have been programmed for the introduction of the instrument.

## INSTRUMENT BEATS VERSUS RHYTHM PROGRAM

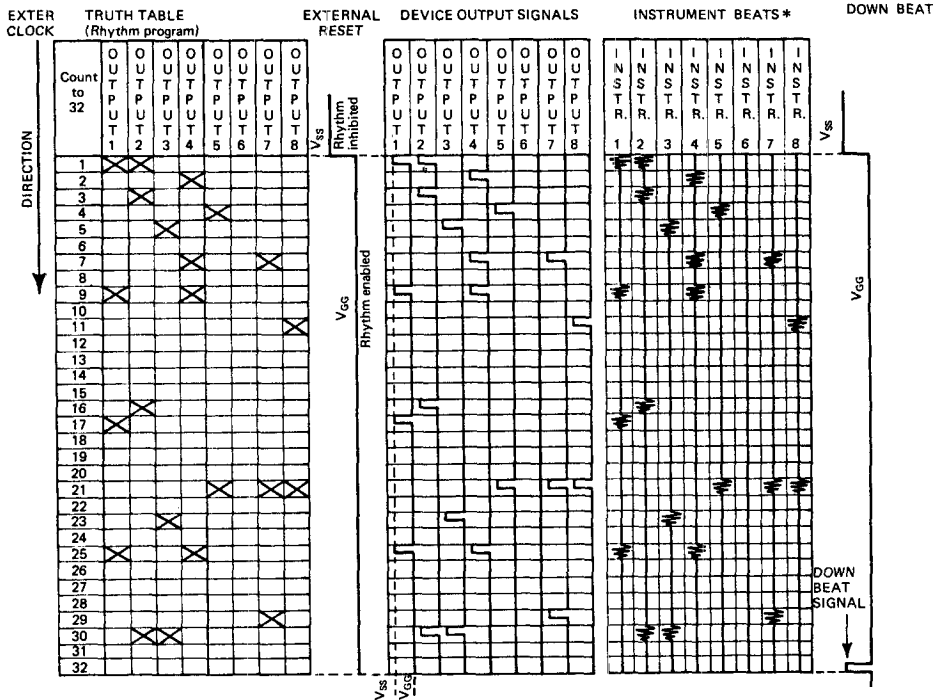

\* The lowering of the music signals depends on the intrinsic decay time of the sound generator and not on the length of the enable pulses. Each beat can therefore last for more than one elementary time

## TYPICAL APPLICATIONS

Figure 1 shows the typical application of the M 253 (AA).

With two M 253 devices it is possible to increase the number of rhythms or the number of instruments available, or the number of elementary times, as shown in figures 2, 3 and 4 respectively.

The use of a memory matrix allows the customer complete flexibility, since modification of the memory is quick and relatively cheap.

Fig. 1 - Rhythm system (standard content)

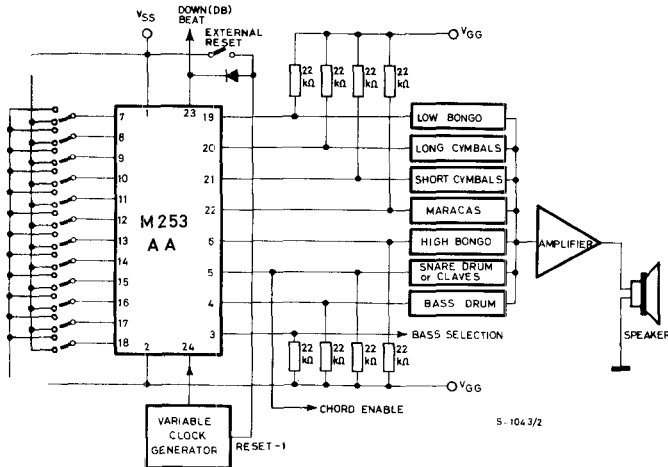
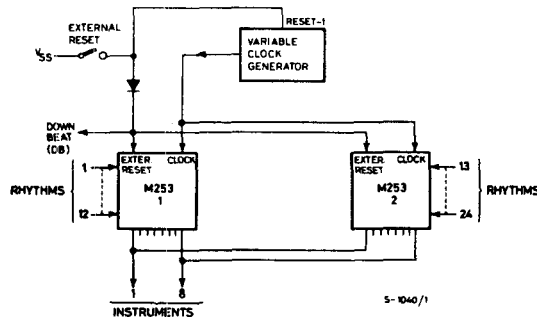

Fig. 2 - Increase in number of rhythms



The rhythms may be selected from both devices simultaneously.

## TYPICAL APPLICATIONS (continued)

Fig. 3 - Increase in number of instruments

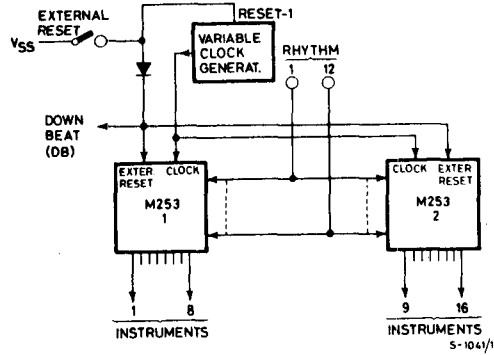
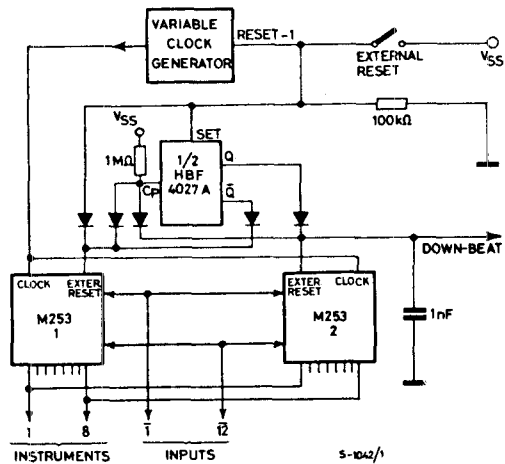

Fig. 4 - Increasing the number of elementary times



Note: The total number of elementary times is given by the sum of the elementary times of the individual devices



## CIRCUIT FOR CHANGING THE NUMBER OF ELEMENTARY TIMES

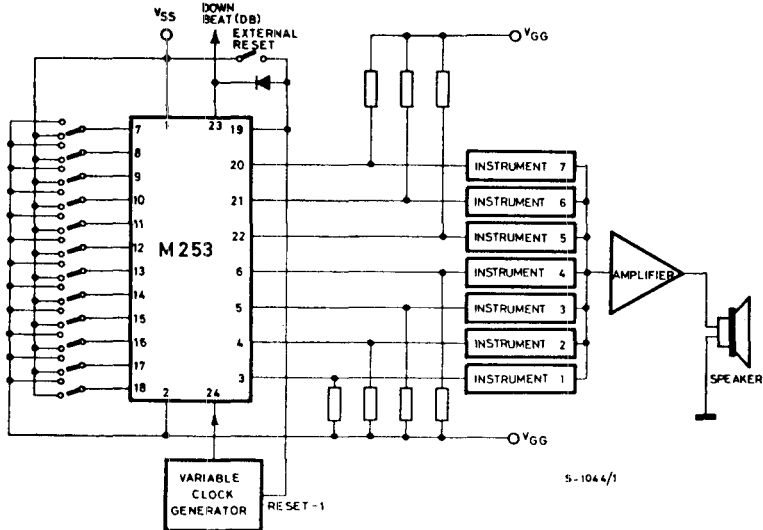

To obtain a required number of elementary times "N" simply put a cross in the "N + 1" position of the column which now represents the reset output, rather than the 8th instrument.

The DB output can be used as down-beat because it appears at the beginning of each measure. Since the pulse is only 2 - 3  $\mu$ s long it must, however, be stretched and buffered to enable it to drive a lamp.

Full information on the use of the M 253 in electronic organs and other applications will be found in Technical Note no. 131 available on request.

## COMPLETING THE TRUTH TABLE

The ROM truth table has been organized in 32 rows which represent elementary times and 96 columns (12 groups of 8) where each group represents a rhythm which has at its disposition 8 programmable instruments. To programme each rhythm one indicates (with a cross) in the appropriate boxes the timing for each beat required for each instrument.

In the given truth table we show an example of how to programme three imaginary rhythms, the first is in 4/4 time, the second in 3/4 time and the third in different time, chosen randomly. Each cross corresponds to a beat of the indicated instrument or, in logic terms, to the presence of a "1" level (positive logic) at the output.

The absence of a cross indicates that the corresponding instrument is not used in that part of the rhythm. Rhythm 3 is an example of how to programme for a time which differs from 4/4 or 3/4. This is achieved by using output 8 to reset the rhythm and not to drive an instrument. The rhythm is valid till elementary time no. 15.



# M 253

COUNT TO 32	RHYTHM 11								RHYTHM 12							
	O U T P U T 1	O U T P U T 2	O U T P U T 3	O U T P U T 4	O U T P U T 5	O U T P U T 6	O U T P U T 7	O U T P U T 8	O U T P U T 1	O U T P U T 2	O U T P U T 3	O U T P U T 4	O U T P U T 5	O U T P U T 6	O U T P U T 7	O U T P U T 8
1																
2																
3																
4																
5																
6																
7																
8																
9																
10																
11																
12																
13																
14																
15																
16																
17																
18																
19																
20																
21																
22																
23																
24																
25																
26																
27																
28																
29																
30																
31																
32																