

NE602 PRIMER

by Joseph J. Carr

THE Signetics (Philips Components) NE602/SA602 is a monolithic integrated circuit containing a double balanced mixer (DBM), an oscillator, and an internal voltage regulator in a single eight-pin package (Fig. 1). The DBM operates to 500 MHz, while the internal oscillator works to 200 MHz. The primary uses of the NE602/SA602 are in HF and VHF receivers, frequency converters and frequency translators. The device can also be used as a signal generator in many popular inductor-capacitor (L-C) based variable frequency oscillator (VFO), piezoelectric crystal (XTAL), or swept-frequency, configurations. In this article we will explore the various configurations for the d.c. power supply, the RF input, the local oscillator and the output circuits. We will also examine certain applications of the device.

Versions

The NE602 version of the device operates over a temperature range of 0 to +70 °C, while the SA602 operates over the extended temperature range of -40 to +85 °C. The most common form of the device is probably the NE602N, which is an eight-pin mini-DIP package. Eight-lead SO Surface mount (D-suffix) packages are also available. In this article the NE602N is featured, although the circuits also work with the other packages and configurations, including the improved follow-up types NE602AN and NE602AD which are now available.

Because the NE602 contains both a mixer and a local oscillator, it can operate as a radio receiver 'front-end' circuit. It provides very good noise and third-order intermodulation performance. The noise figure is typically 5 dB at a frequency of 45 MHz. The NE602 has a third-order intercept point of about -15 dBm referenced to a matched input, although it is recommended that a maximum signal level of -25 dBm (approx. 3.16 mW) be observed. This signal level corresponds to about 12.6 mV into a 50-Ω load, or 68 mV into the 1,500-Ω input impedance of the NE602. The NE602 is capable of providing 0.2-μV sensitivity in receiver circuits without external RF amplification. One criticism of the NE602 is that it appears to sacrifice some dynamic range for high sensitivity—a problem said to be solved in the A-series (e.g., NE602AN).

Frequency conversion/translation

The process of frequency conversion is

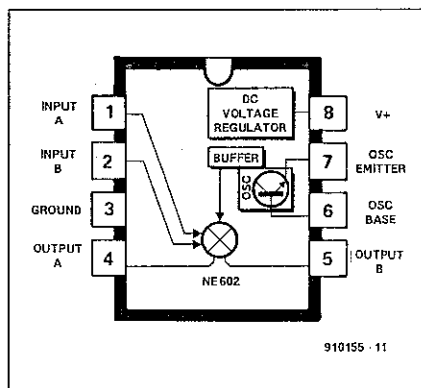

Fig. 1. Block diagram of the NE602 showing pinouts.

called heterodyning. When two signals at different frequencies (f_1 and f_2) are mixed in a non-linear circuit, a collection of different frequencies will appear at the output of the circuit. These are characterized as f_1 , f_2 and $nf_1 \pm mf_2$, where n and m are integers. In most practical situations, n and m are 1, so the total output spectrum will consist at least of f_1 , f_2 , $f_1 + f_2$ and $f_1 - f_2$. Of course, if the two input cir-

cuits contain harmonics, additional products are found in the output. In superheterodyne radio receivers, either the sum or difference frequency is selected as the intermediate frequency (IF). In order to make the frequency conversion possible, a circuit needs a local oscillator (LO) and a mixer circuit (both of which are provided in the NE602).

The local oscillator consists of a VHF n-p-n transistor with the base connected to pin 6 of the NE602, and the emitter to pin 7; the collector of the oscillator transistor is not available on an external pin. There is also an internal buffer amplifier which connects the oscillator transistor to the DBM circuit. Any of the standard oscillator circuit configurations can be used with the internal oscillator, provided that access to the collector terminal is not required. Thus, Colpitts, Clapp, Hartley, Butler and other oscillator circuits can be used with the NE602 device, while the Pierce and Miller oscillator circuits are not.

The double balanced mixer (DBM) circuit is shown in Fig. 2; it consists of a pair of cross-connected differential amplifiers (T1-T2 with T5 as a current source; similarly T3/T4 with T6 working as a current source).

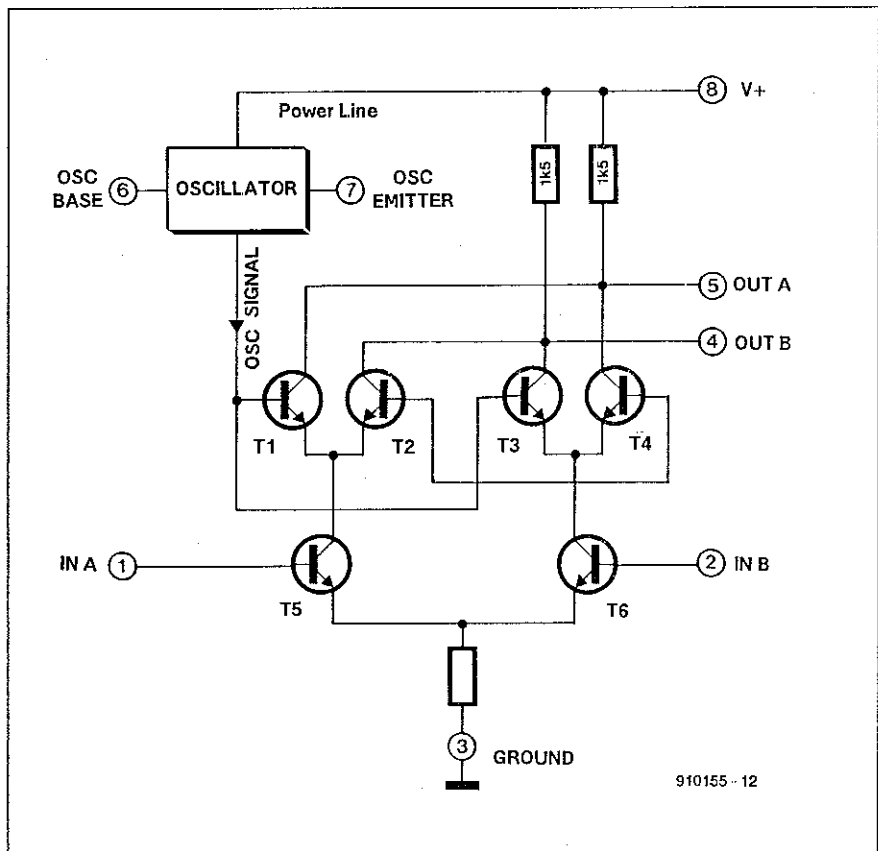

Fig. 2. Partial internal schematic showing the Gilbert Transconductance Cell.

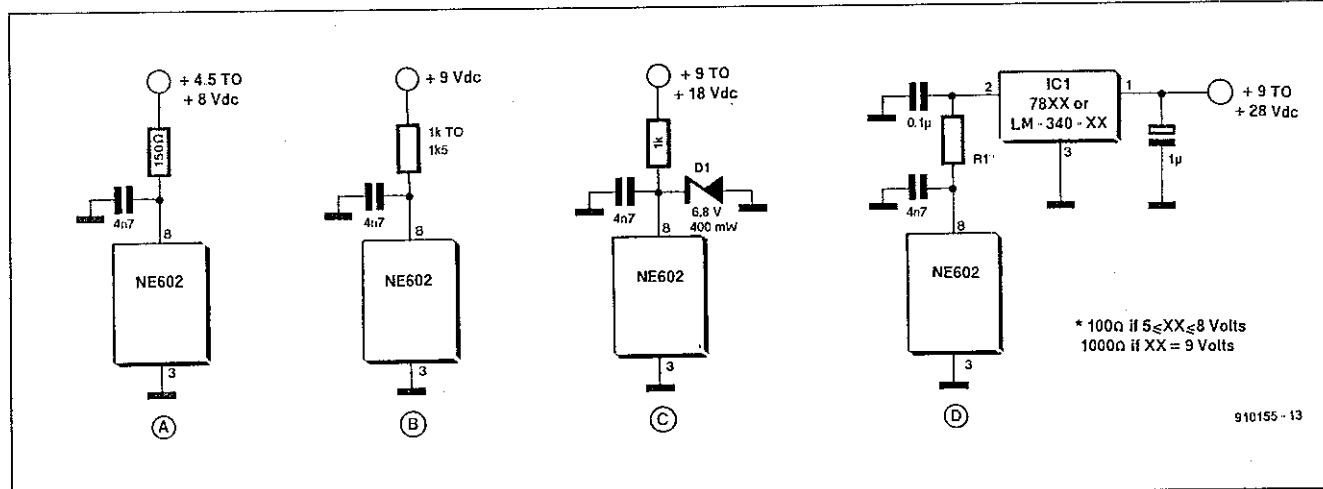

Fig. 3. DC power supply configurations for the NE602: a) for supplies +4.5V to +8 V; b) for +9-V supplies; c) zener diode regulator for +9 to +18 V supplies; d) 3-terminal IC voltage regulator for supplies from +8 to +28 V

This configuration is called a Gilbert Transconductance Cell. The cross-coupled collectors form a push-pull output (pins 4 and 5) in which each output pin is connected to the V+ power supply terminal through 1,500- Ω resistors. The input is also push-pull, and similarly is cross-coupled between the two halves of the cell. The local oscillator signal is injected into each cell-half at the base of one of the transistors.

Because the mixer is double-balanced, it has a key attribute that makes it ideal for use as a frequency converter or receiver front-end: suppression of the LO and RF input signals in the outputs. In the NE602 chip, the output signals are f_1+f_2 and f_1-f_2 . Although some harmonic products appear, many are also suppressed because of the DBM action

DC power supply connections

The V+ power supply terminal of the NE602 is pin 8 and the ground connection is pin 3; both must be used for the d.c. power connections. The d.c. power supply range is to be +4.5 V to +8 V d.c., with a current drain ranging from 2.4 to 2.8 mA.

It is highly recommended that the V+ power supply terminal (pin 8) be bypassed to ground with a capacitor of 10 nF to 100 nF. The capacitor should be mounted as close to the body of the NE602 as is practical; short leads are required in radio frequency (RF) circuits.

Figure 3a shows the recommended power supply configuration for situations where the supply voltage is +4.5 to +8 V. For best results, the supply voltage should be regulated. Otherwise the local oscillator frequency may not be stable, which leads to problems. A series resistor (100 to 180 Ω) is placed between the V+ power supply rail and the V+ terminal on the NE602. If the power supply voltage is raised to +9 V, increase the value of the series resistance an order of magnitude to 1,000 to 1,500 Ω (Fig. 3b).

If the d.c. power supply voltage is either

unstable, or above +9 V, it is highly recommended that a means of voltage regulation be provided. In Fig. 3c a zener diode is used to regulate the NE602 V+ voltage to 6.8 V, even though the supply voltage ranges from +9 V to +18 V (a situation found in automotive applications). An alternative voltage regulator circuit is shown in Fig. 3d. This circuit uses a three-terminal voltage regulator to provide V+ voltage to the NE602. Because the NE602 is a very low current drain device, the lower power versions of the regulators (e.g., 78Lxx) can be used. The low-power versions also permit the NE602 to have its own regulated power supply, even though the rest of the radio receiver uses a common d.c. power supply. Input voltages of +9 V to more than +28 V, depending on the regulator device selected, can be used for this purpose. The version of Fig. 3d uses a 78L09 to provide +9 V to the NE602, although the 78L05 and 78L06 can also be used to good effect.

NE602 input circuits

The RF input port of the NE602 uses pins 1 and 2 to form a balanced input. As is often the case in differential amplifier RF mixers, the RF input signals are applied to the base terminals of the two current sources (T₅ and T₆ in Fig. 2). The input impedance of the NE602 is 1,500 Ω shunted by 3 pF at lower frequencies, but drops to about 1,000 Ω in the VHF region.

Several different RF input configurations are shown in Fig. 4; both single-ended (unbalanced) and differential (balanced) input circuits can be used with the NE602. In Fig. 4a a capacitively coupled untuned, unbalanced input scheme is shown. The signal is applied to pin 1 (although pin 2 could have been used instead) through a capacitor, C₁, that has a low impedance at the operating frequency. The signal level should be less than -25 dBm, or about 68 mV into 1,500 Ω (180 mV_{pp}). Whichever input is used, the alternative input is unused, and should be bypassed to ground through a low-value capacitor (1 nF to 100 nF depend-

ing on frequency).

A wideband transformer-coupled RF input circuit is shown in Fig. 4b. In this configuration, a wideband RF transformer is connected such that the secondary is applied across pins 1 and 2 of the NE602, with the primary of the transformer connected to the signal source or aerial. The turns ratio of the transformer can be used to raise the source impedance to 1,500 Ω (the NE602 input impedance). Either conventional or toroidal transformers can be used for T₁₁. As in the previous circuit, one input is bypassed to ground through a low reactance capacitor.

Tuned RF input circuits are shown in Figs. 4c, 4d, 4e and 5. Each of these circuits performs two functions: a) it selects the desired RF frequency while rejecting others, and b) it matches the 1.5-k Ω input impedance of the NE602 to the source or aerial system impedance (e.g., 50 Ω). The circuit shown in Fig. 4c uses an inductor (L1) and capacitor (C1) tuned to the input frequency, as do the other circuits, but the impedance matching function is done by tapping the inductor; a d.c. blocking capacitor is used between the aerial connection and the coil. A third capacitor, C₃, is used to bypass one of the inputs (pin 2) to ground.

Another version of the circuit is shown in Fig. 4d. It is similar in concept to the previous one, but uses a tapped capacitor voltage divider (C₂-C₃) for the impedance matching function. Resonance with the inductor is established by the combination of C₁, the main tuning capacitor, in parallel with the series combination of C₂ and C₃:

$$C_{\text{tune}} = C_1 + (C_2 C_3) / (C_2 + C_3) \quad [1]$$

The previous two circuits are designed for use when the source or aerial system impedance is smaller than 1.5 k Ω (the input impedance of the NE602). The circuit of Fig. 4e can be used in all three situations: input impedance lower than, higher than, or equal to the NE602 input impedance, depending on the ratio of the number of turns in the primary

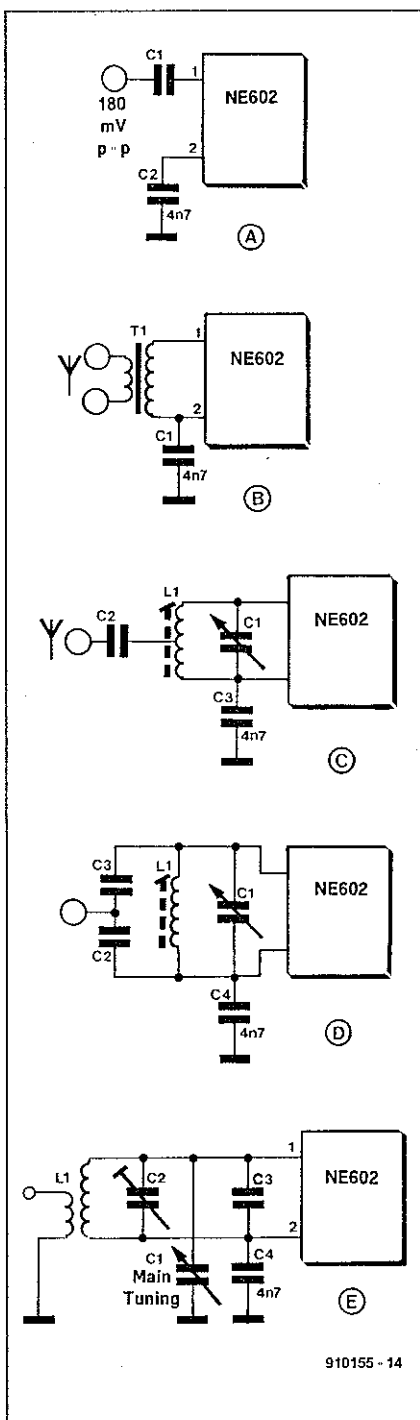

Fig. 4 NE602 input circuit configurations: a) direct, untuned input ($V_{in} \leq 180$ mV_{pp}); b) broadbanded RF transformer couples signal and transform aerial impedance to 1500 Ω ; c) tuned input uses a tap on the inductor for impedance matching; d) tuned input uses a tapped capacitor voltage divider for impedance matching; e) tuned transformer input that uses a grounded frame variable capacitor.

winding (L2) to the number of turns in the secondary winding (L1). The situation shown schematically in Fig. 4e is for the case where the source impedance is smaller than the input impedance of the NE602.

The secondary of the RF transformer (L1)

resonates with a capacitance made up of C1 (main tuning), C2 (trimmer tuning or bandspread), and a fixed capacitor, C3. An advantage of this circuit is that the frame of the main tuning capacitor is grounded. This feature is an advantage because most tuning capacitors are designed for grounded frame operation, so construction is easier. In addition, most of the variable frequency oscillator circuits (discussed shortly) used with the NE602 also have a grounded frame capacitor. The input circuit of Fig. 4e can therefore use a single dual-section capacitor for single knob tuning of both RF input and local oscillator.

Figure 5 shows a tuned input circuit that relies, at least in part, on a voltage variable capacitance (varactor or varicap) diode for the tuning function. The total tuning capacitance that resonates transformer secondary L2 is the parallel combination of C1 (trimmer), C2 (a fixed capacitor), and the junction capacitance of varactor diode D1. The value of capacitor C3 is normally chosen large compared with the diode capacitance so that it will have little effect on the total capacitance of the series combination C3/CD1. In other cases, however, the capacitance of C3 is chosen close to the capacitance of the diode so it becomes part of the resonant circuit capacitance.

A varactor diode is tuned by varying the reverse bias voltage applied to it. Tuning voltage V_T is set by a voltage divider consisting of R1, R2 and R3. The main tuning potentiometer (R1) can be a single-turn model, but for best resolution of the tuning control use a multiturn potentiometer. The fine tuning potentiometer can be a panel mounted model for use as a bandspread control, or a trimmer model for use as a fine adjustment of the tuning circuit (a function also shared by trimmer capacitor C1).

The voltage used for the tuning circuit (V_A) must be well regulated, or the tuning will shift with variations of the voltage. Some designers use a separate three-terminal IC regulator for V_A , but that is not strictly necessary. A more common solution is to use a single low-power 9-V three-terminal IC voltage regulator for both the NE602 and the tuning network. However, it will only work when the diode needs no more than +9 V for correct tuning of the desired frequency range. Unfortunately, many varactor diodes require a voltage range of about +1 V to +37 V to cover the entire range of available capacitance.

When oscillator circuits are discussed, we will also see a version of the Fig. 5 circuit that is tuned by a sawtooth waveform (for swept-frequency operation) or a digital-to-analogue converter (for computer-controlled frequency selection).

NE602 output circuits

The NE602 output circuit consists of the cross-coupled collectors of the two halves of the Gilbert transconductance cell (Fig. 2), and are available on pins 4 and 5. In general, it makes no difference which of these pins is

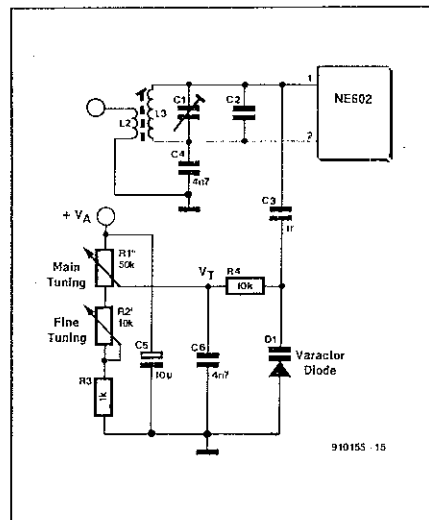

Fig. 5. Voltage-tuned RF input circuit.

used for the output — in single-ended output configurations only one terminal is used, and the other one is ignored. Each output terminal is connected internally to the NE602 to $V+$ through separate 1.5-k Ω resistors.

Figure 6a shows the wideband, high impedance (1.5-k Ω) output configuration. Either pin 4 or 5 (or both) can be used. A capacitor is used to provide d.c. blocking. This capacitor should have a low reactance at the frequency of operation, so values between 1 nF and 100 nF are generally selected.

Transformer output coupling is shown in Fig. 6b. In this circuit, the primary of a transformer is connected between pins 4 and 5 of the NE602. For frequency converter or translator applications, the transformer could be a broadband RF transformer wound on either a conventional slug-tuned form or a toroid form. For direct conversion autodyne receivers the transformer would be an audio transformer. The standard 1:1 transformers used for audio coupling can be used. These transformers are sometimes marked with impedance ratio rather than turns ratio (e.g. 600 Ω :600 Ω , or 1.5k Ω :1.5k Ω).

Frequency converters and translators are the same thing, except that the 'converter' terminology generally refers to a stage in a superhct receiver, while 'translator' is more generic. For these circuits, the broadband transformer will work but it is probably better to use a tuned RF/IF transformer for the output of the NE602. The resonant circuit will reject all but the desired frequency product; e.g., the sum or difference (IF) frequency. Figure 6c shows a common form of resonant output circuit for the NE602. The tuned primary of the transformer is connected across pins 4 and 5 of the NE602, while a secondary winding (which could be tuned or untuned) is used to couple the signal to the following stages.

A single-ended RF tuned transformer output network for the NE602 is shown in Fig. 6d. In this coupling scheme, the output terminal of the IC is coupled to the $V+$ supply rail through a tuned transformer. Perhaps a better solution to the single-ended problem is the circuit of Fig. 6e. In this cir-

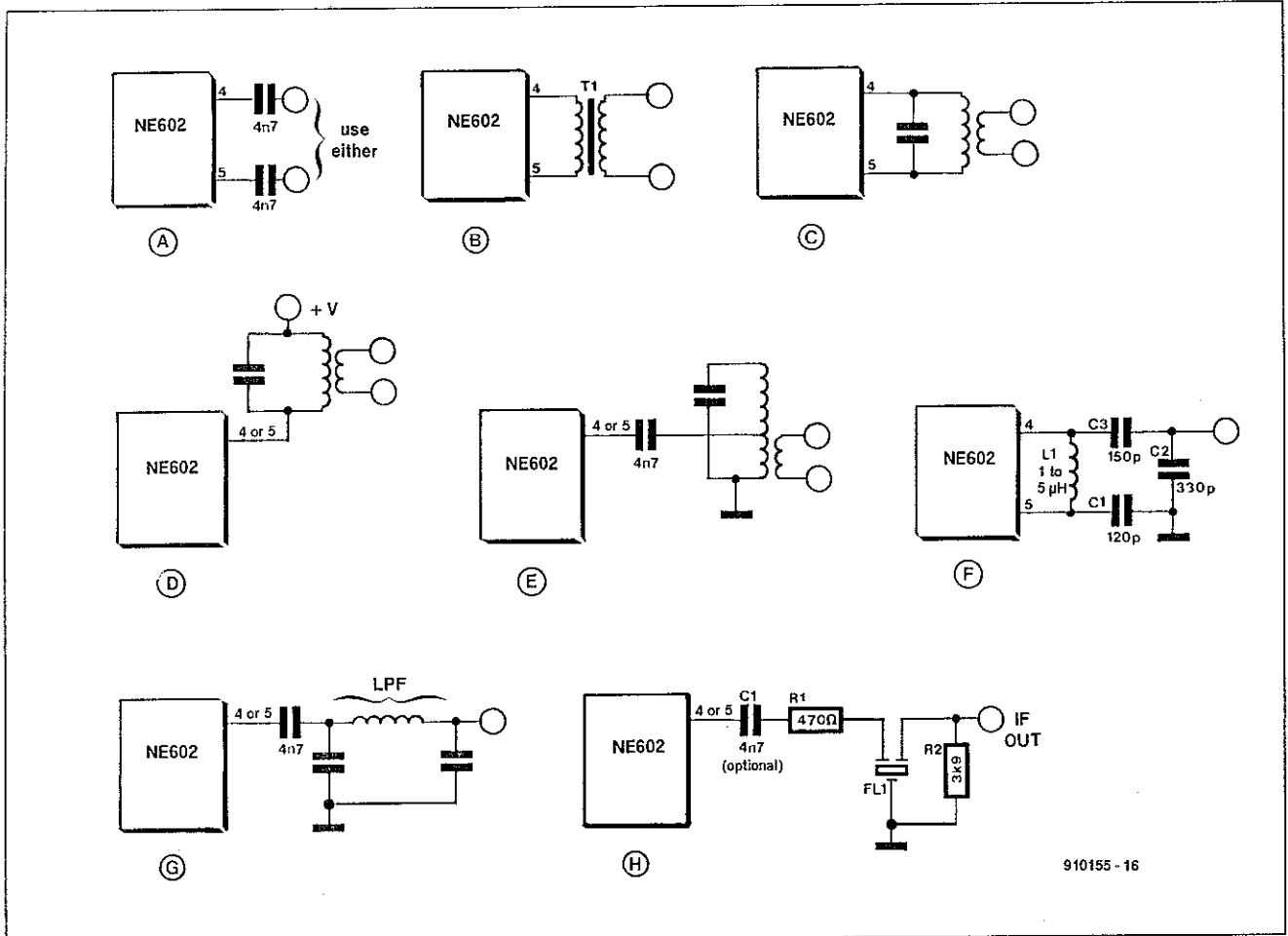

Fig. 6. Output circuit configurations: a) direct capacitor coupled output (untuned); b) broadband transformer coupled output; c) tuned transformer output; d) tuned transformer to V+; e) grounded tuned transformer output; f) tapped capacitor tuned output (VHF circuits); g) low-pass filter output; h) filter output.

circuit, the transformer primary is tapped for a low impedance, and the tap is connected to the NE602 output terminal through a d.c. blocking capacitor. These transformers are easily available as either 455 kHz or 10.7 MHz versions, and may also be made relatively easily.

Still another single-ended tuned output circuit is shown in Fig. 6f. In this circuit, one of the outputs is grounded for RF frequencies through a capacitor. Tuning is a function of the inductance of L1 and the combined series capacitance of C1, C2 and C3. By tapping the capacitance of the resonant circuit, at the junction of C2-C3, it is possible to match a lower impedance (e.g. 50 Ω) to the 1.5-kΩ output impedance of the NE602.

The single-ended output network of Fig. 6g uses a low-pass filter as the frequency selective element. This type of circuit can be used for applications such as a heterodyne signal generator in which the local oscillator frequency of the NE602 is heterodyned with the signal from another source applied to the RF input pins of the IC. The difference frequency is selected at the output when the low-pass filter is designed such that its cut-off frequency is between the sum and difference frequencies.

In Fig. 6h an IF filter is used to select the

desired output frequency. These filters are available in a variety of different frequencies and configurations, including the Collins mechanical filters that were once used extensively in high-grade communications receivers (260 kHz, 455 kHz and 500 kHz centre frequencies). Current high-grade communications receivers typically use crystal IF filters centred on 8.83 MHz, 9 MHz, 10.7 MHz or 455 kHz (with bandwidths of 100 Hz to 30 kHz). Even broadcast radio receivers can be found using IF filters. Such filters are made of piezoceramic material, and are usually centred on either 260 or 262.5 kHz (AM auto radios), 455 or 460 kHz (other AM radios) or 10.7 MHz (FM radios). The lower frequency versions are typically made with 4-, 6- or 12-kHz bandwidths, while the 10.7-MHz versions have bandwidths of 150 to 300 kHz (200 kHz being most common).

In the circuit of Fig. 6h it is assumed that the low-cost (typically US\$ 3) ceramic AM or FM filters are used (for other types, compatible resistances or capacitances are needed to make the filter work properly). The input side of the filter (FL1) in Fig. 6h is connected to the NE602 through a 470-Ω resistor and an optional d.c. blocking capacitor (C1). The output of the filter is terminated

into a 3.9-kΩ resistor. The difference IF frequency resulting from the conversion process appears at this point.

One of the delights of the NE602 chip is that it contains an internal oscillator circuit that is already coupled to the internal double balanced mixer. The base and emitter connections to the oscillator transistor inside the NE602 are available through pins 6 and 7, respectively. The internal oscillator can be operated at frequencies up to 200 MHz. The internal mixer works to 500 MHz. If higher oscillator frequencies are needed, use an external local oscillator. An external signal can be coupled to the NE602 through pin 6, but must be limited to no more than about -13 dBm, or 250 mV across 1,500 Ω.

NE602 local oscillator circuits

There are two general methods for controlling the frequency of a local oscillator circuit: inductor-capacitor (LC) resonant circuits or piezoelectric crystal resonators. We will consider both forms, but first the crystal oscillators.

Figure 7a shows the basic Colpitts crystal oscillator. It will operate with fundamental

mode crystals on frequencies up to about 20 MHz. The feedback network consists of a capacitor voltage divider (C1-C2). The values of these capacitors are critical, and may be calculated from:

$$C_1 = 100 / \sqrt{F} \quad [2]$$

$$C_2 = 1000 / F \quad [3]$$

Where the capacitor values are in pF and the frequency in MHz. The values resulting from these equations are approximate, but work well under circumstances where external stray capacitance does not dominate the total. However, the practical truth is that capacitors come in standard values and these may not be exactly the values required by Eqs [2] and [3].

When the capacitor values are correct the oscillation will be consistent. If you pull the crystal out, and then reinsert it, the oscillation will restart immediately. Also, if the power is turned off and then back on again, the oscillator will always restart. If the capacitor values are incorrect, the oscillator will either fail to run at all, or will operate intermittently. Generally, an increase in the capacitances will suffice to make operation consistent.

A problem with the circuit of Fig. 7a is that the crystal frequency is not controllable. The actual operating frequency of any crystal depends, in part, on the circuit capacitance seen by the crystal. The calibrated frequency is typically valid when the load capacitance is 20 pF or 32 pF, but this can be specified to the crystal manufacturer at the time of ordering. In Fig. 7b a variable capacitor is placed in series with the crystal in order to set the frequency. This trimmer can be adjusted to set the oscillation frequency to the desired frequency.

The two previous crystal oscillators operate in the fundamental mode. The resonant frequency in the fundamental mode is set by the dimensions of the slab (wafer) of quartz used for the crystal—the thinner the slab, the higher the frequency. Fundamental mode crystals work reliably up to about 20 MHz, but above 20 MHz the slabs become too thin for safe operation. Above about 20 MHz, the thinness of the slabs of fundamental mode crystal causes them to fracture easily. An alternative is to use overtone crystals. The overtone frequency of a crystal is not necessarily an exact harmonic of the fundamental frequency, but is close to it. The overtones tend to be close to odd integer multiples of

the fundamental (3rd, 5th, 7th). Overtone crystals are marked with the appropriate overtone frequency, rather than the fundamental.

Figures 7c and 7d are overtone mode crystal oscillator circuits. The circuit in Fig. 7c is the Butler oscillator. The overtone crystal is connected between the oscillator emitter of the NE602 (pin 7) and a capacitive voltage divider that is connected between the oscillator base (pin 6) and ground. There is also an inductor in the circuit (L1) and this must resonate with C1 to the overtone frequency of crystal X1. Figure 7c can use either 3rd or 5th overtone crystals up to about 80 MHz. The circuit in Fig. 7d is a third-overtone crystal oscillator that works from 25 MHz to about 50 MHz, and is simpler than Fig. 7c.

A pair of variable frequency oscillator (VFO) circuits are shown in Figs. 7e and 7f. The circuit in Fig. 7e is the Colpitts oscillator, while Fig. 7f is the Hartley oscillator. In both oscillators, the resonating element is an LC tuned resonant circuit. In Fig. 7e, however, the feedback network is a tapped capacitive voltage divider, while in Fig. 7f it is a tap on the resonating inductor. In both cases, a d.c. blocking capacitor to pin 6 is needed to pre-

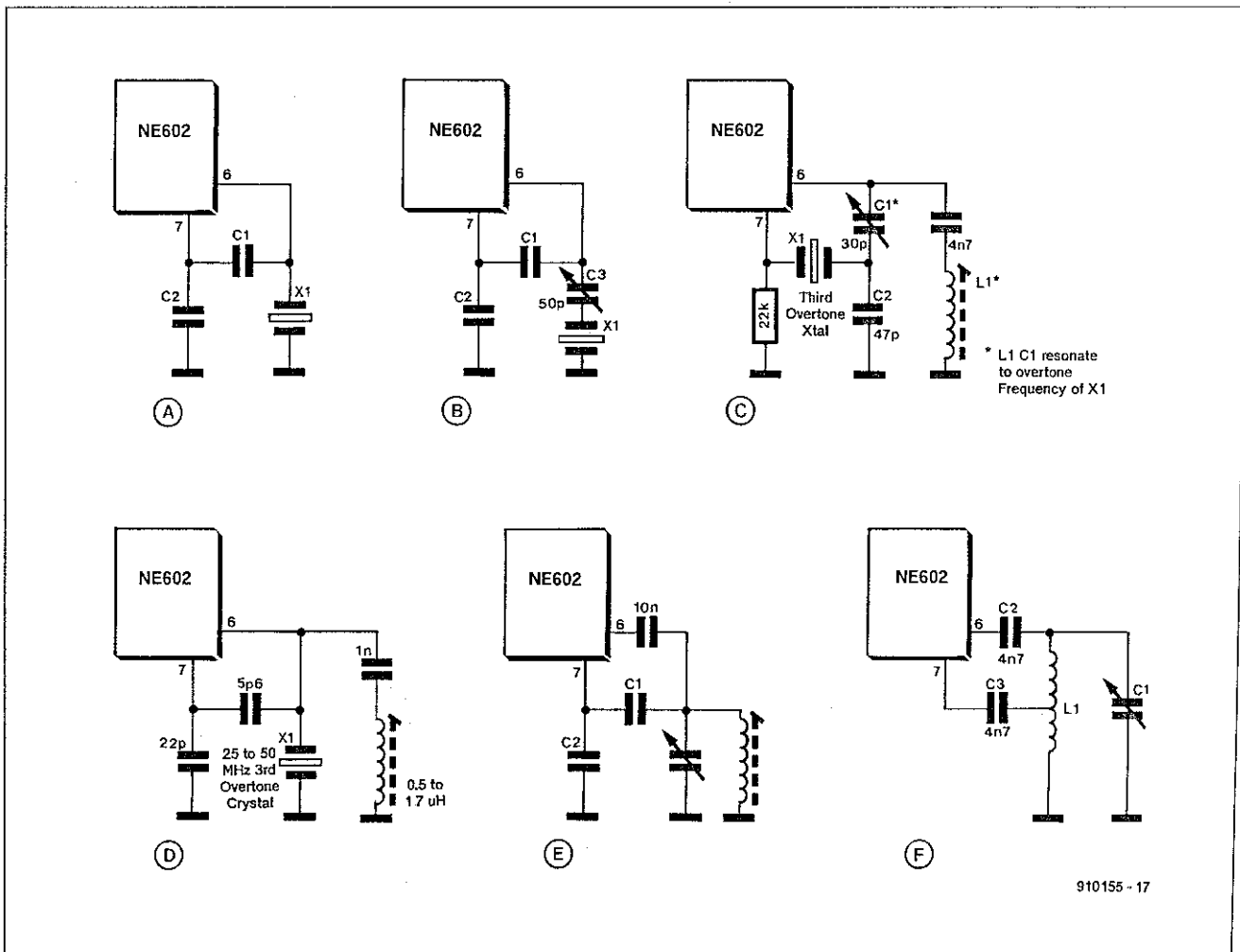

Fig. 7 Local oscillator circuits for the NE602: a) simple Colpitts crystal oscillator; b) Colpitts crystal oscillator with adjustable frequency control; c) Butler overtone oscillator for low-band VHF; d) additional overtone oscillator; e) Colpitts VFO; f) Hartley VFO.

vent the oscillator from being d.c.-grounded through the resistance of the inductor

Voltage-tuned NE602 oscillator circuits

Figure 8 shows a pair of VFO circuits in which the capacitor element of the tuned circuit is a variable capacitance diode, or varactor (D1 in Figs 8a and 8b). These diodes exhibit a junction capacitance that is a function of the reverse bias potential applied across the diode. Thus, the oscillating frequency of these circuits is a function of tuning voltage, V_t . The version shown in Fig. 8a is the parallel-resonant Colpitts oscillator, while that in Fig. 8b is the series-tuned Clapp oscillator.

Figure 9 shows an application of the voltage-tuned oscillator (in this example, the Clapp oscillator). Two tuning modes are provided in Fig. 9. When switch S1 is in position 'A', the tuning voltage is manually set with a potentiometer, R2. If a d.c. level is applied to the top end of the potentiometer, the oscillator will operate on a discrete frequency that is a function of V_{TA} . If a sinusoidal waveform is applied to the potentiometer, however, the oscillator frequency will deviate back and forth in frequency modulation (FM). Or, if a sawtooth waveform is applied, the circuit becomes a sweep oscillator: the frequency will increase as the applied voltage increases, and then snap back to the lowest frequency in its

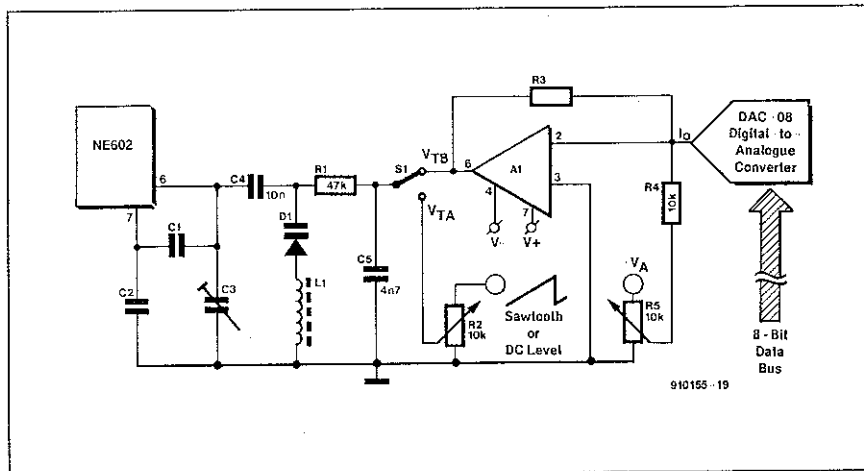

Fig. 9 LO frequency control by either manual or digital means, according to the setting of switch S1. This circuit can be swept for FM or sweep generator use, or computer controlled by applying a binary word to the DAC input corresponding to the desired drive voltage for a specified frequency.

range when the sawtooth drops back to zero.

When switch S1 is in position 'B', the frequency is controlled by a digital-to-analogue converter (DAC). In this case a current output device (DAC-08 or its relatives) is shown. The output of the DAC is a current between 0 and 2 mA, which is converted into a voltage by operational amplifier A1. The tuning voltage V_{TB} is the product $I_o R_3$. A d.c. offset, for trimming the actual frequency, is provided by potentiometer R5 and a negative reference d.c. source, V_A .

There are several advantages to the DAC-driven version of this circuit. One is to digitally control the sweep in a manner similar to the analogue sawtooth waveform. If the digital inputs of the DAC are cycled through the binary numbers 00 to FF hex (i.e., 255 decimal) in sequence, the analogue output rises as a sawtooth.

Another application is to let the computer set the frequency of the oscillator. When the circuit is calibrated, you can set one of 256 discrete frequencies by sending the correct binary number to the DAC (which, of course, corresponds to a discrete voltage).

Finally, the digitally driven voltage-controlled oscillator can be programmed for a more linear frequency characteristic. Varactor diodes have a non-linear voltage vs frequency characteristic, and therefore a non-linear frequency characteristic in a resonant circuit. A linearized look-up table stored in the computer can be used to generate the voltage that produces a series of equal discrete frequency steps for each 1-LSB change of the applied binary word.

NE602 as an oscillator

The NE602 is usually thought to be a receiver or frequency converter, but it can also be used as an oscillator or signal generator. Normally, the LO signal and the RF signal are suppressed in the output. Figure 10 shows a generic circuit that will allow the LO signal to appear at the output (no RF or IF signal appears). In this circuit, one RF input (pin 2) is bypassed to ground for RF, while

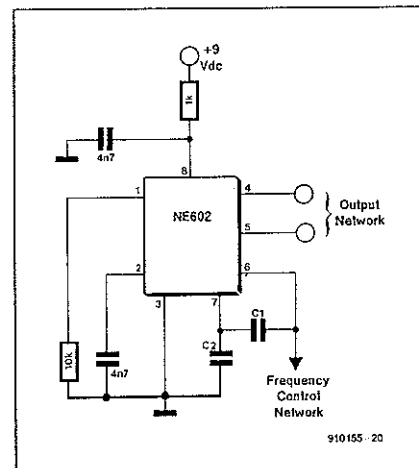

Fig. 10. Method for using the NE602 as a signal generator.

the other input (pin 1) is grounded for d.c. through a 10-kΩ resistance.

Conclusion

The NE602 is a well-behaved RF chip that will function in a variety of applications from receivers, to converters, to oscillators, to signal generators. Good luck. ■

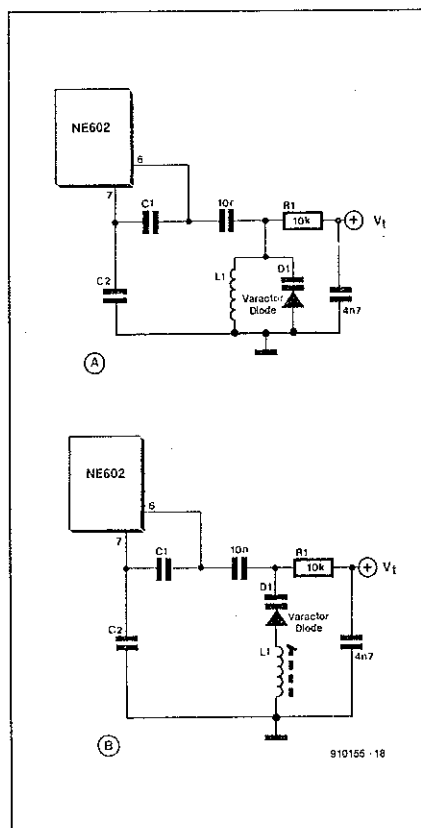

Fig. 8. Voltage-tuned (varactor) VFO circuits: a) Colpitts; b) Clapp.